

DIGITAL INDICATOR SMART
S_DIAL WORK CBG



Discover our brand new S_Dial CBG Smart, for internal two-point bore measurements. More efficiency and easy to use, with integrated Bluetooth® Technology.

Bore gauges

The digital indicator can be used with different types of bore gauges.

Preset

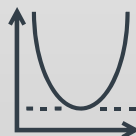
The Preset is made by one single click on the Master button.

Min value

Introduction of the Preset value on the saved Min value

TECHNICAL FEATURES

- Special version for cylindrical bore gauges
- Data output Power, Proximity & Bluetooth®
- Introduction of the Preset value on the saved Min value
- Quick measure of the reversal point
- Robust construction
- Water and coolant resistant
- Broad choice of functions (MIN/MAX/DELTA, TOL, PRESET, AUTO OFF, etc.)
- Automatic wake-up and sleeping mode, Absolute System S.I.S*
- Maximum error of 3 µm

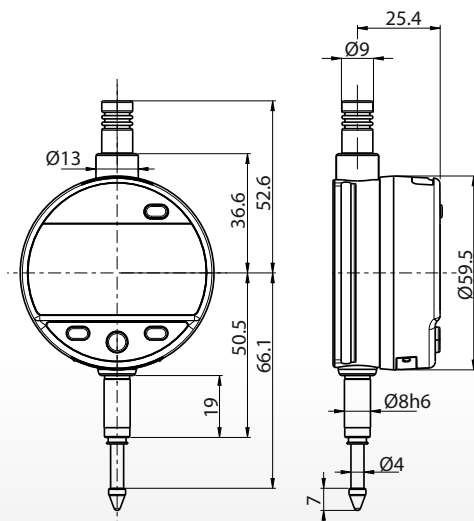

TECHNICAL DATA

Specifications		805.6317
Measuring range	mm	12.5
Resolution	mm	0.001
Error max. fe	µm	3
Repeatability	µm	2
Functions	mm/inch, preset (max 999.999) min/max/delta, tolerances, resolution, direction of measurement, 4 references, automatic or manual switch off, key lock	
Output data	Bluetooth® wireless Technology/USB/RS232	
Protection	IP54	

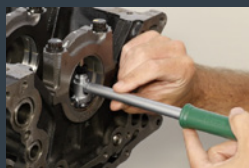

S_Dial Work CBG, easy, quick and reliable measurements.

The Bluetooth® word mark and logos are registered trademarks owned by the Bluetooth SIG, Inc. and any use of such marks by Sylvac is under license. Other trademarks and trade names are those of their respective owners.