



INSTRUCTIONS

MODE D'EMPLOI

BEDIENUNGSANLEITUNG

PLC DIAL GAUGE

E



COMPARATEUR PLC

F

PLC MESSUHR

D



No. 0  No. 0 (0,4x2,5mm) 

Replacing the PLC cable

Remplacement du câble PLC

Austausch des PLC Kabel



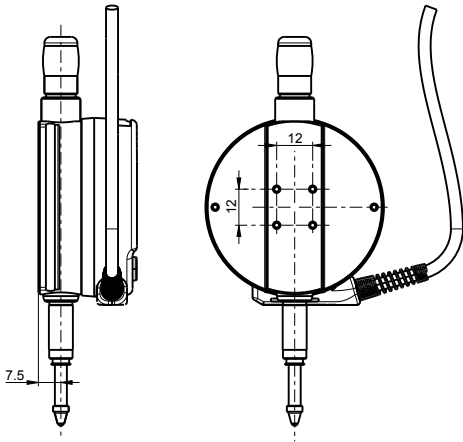
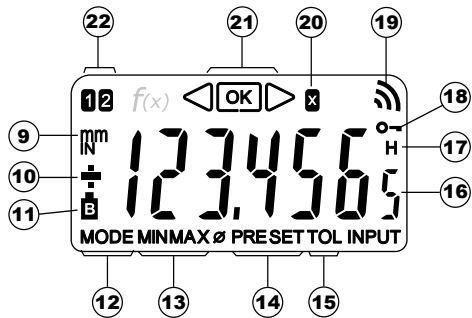
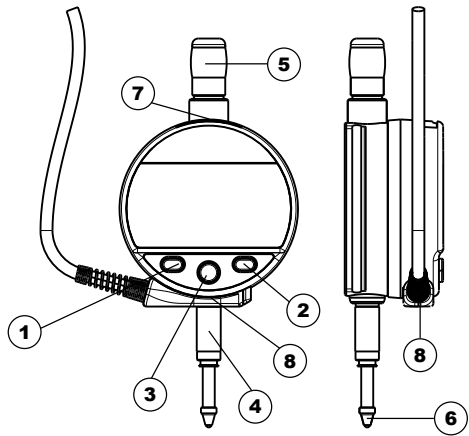

Diagram for rear fixings

Schéma de fixation arrière

Schema für die Befestigung hinten

E

Description



1. MODE button
2. SET button
3. "Favourite" button
4. Clamping shaft $\varnothing 8$ or $3/8$ "
5. Lifting cap
6. Contact point $\varnothing 2/M2.5$ or 4-48-UNF
7. Slot for Proximity cable
8. PLC connector
9. Measurement units (mm/INCH)
10. +/- Indicator
11. Power supply voltage too low
12. Mode menu display
13. MIN/MAX/DELTA mode
14. Preset mode
15. Tolerance mode
16. 6-digit display
17. Hold measured value
18. Button lock
19. Send data
20. Multiplication factor
21. Tolerance indicators
22. Active reference

E

Introduction

Using its digital outputs the PLC comparator supplies a high performance measurement tolerance judgment to an external automatic controller (good part, rework or scrap). Two configurable digital inputs permit the instrument to be reinitialised for a new measurement. Tolerances and other measurement parameters can be configured directly with the instrument buttons. A USB/RS232 (Proximity) connection and a field bus connection (MODBUS / ASCII / ORBIT) allow direct dialogue with the automatic controller or with another data acquisition application (SPC).

1 . Operating features of the instrument

-  The instrument has two operating modes: basic functions (direct access) and advanced functions. In addition to the configuration functions, 2 working reference functions can be accessed, in MIN, MAX and DELTA (TIR) mode, plus tolerance display or input of multiplication factor other than 1:1 (see chaps. 3 and 4)
-  The «favourite» key gives direct access to the function used most often (see chap. 6)
-  Sets a Preset value, resets the MIN/MAX mode, verifies a selection, and controls switching off the instrument.

- Personalising the functions

It is possible to activate or de-activate certain functions of the instrument via RS232 (see chap. 9)

- Data transmission parameters (RS-232 port, default values)

4800Bds, 7 bits, even parity, 2 stop bits

Data transmission parameters (RS-485 port, default values)

128'000Bds, 8 bits, even parity, 1 stop bit

2. Basic functions

Each short press on  gives direct access to the basic functions:

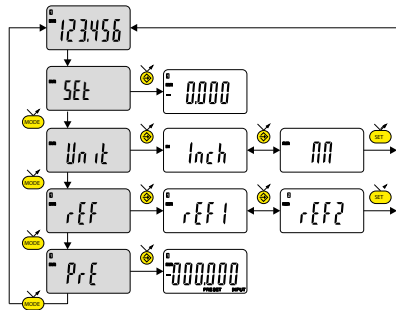

.....Normal mode: Zero setting

.....Units selection (mm or Inch)

.....Choice of reference (REF1 ou REF2)

.....Inputting a Preset value

 next digit

 0...9

 save PRESET

Note: It is possible to assign a different preset value to each of the 2 References. Similarly, different tolerance limits can be assigned to References 1 and 2.

3. Advanced functions

Prolonged pressure (>2s) on **MODE** gives access to the advanced functions. Then, each short press on **MODE** accesses the required function :

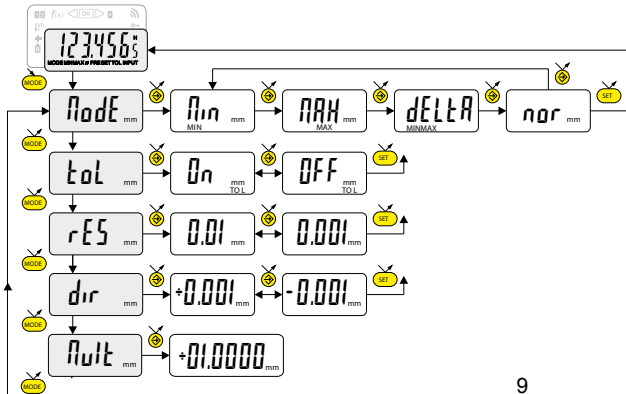

MIN MAX measurement
DELTA (TIR)

Tolerance display
(inputting tolerance limits, see chap. 5)

Resolution choice 0.01 ↔ 0.001

Choice of measurement direction
(positive or negative sense)

Entering a multiplication factor other than 1.0000.
 ↙ Next digit ↘ **SET** 0...9 ↘ **MODE** save the multiplier

..... following

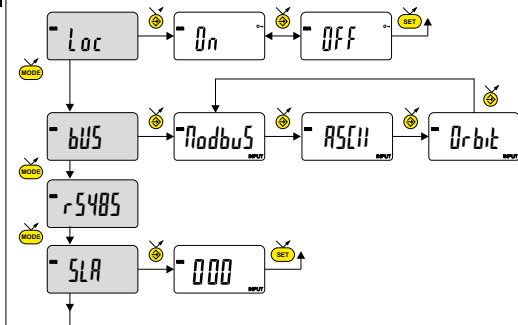

Keyboard locked

Only the favourite key  remains active

Communication protocol selection

RS-485 port configuration (see chapter 6)

Modbus slave address entry

 Next digit  0...9  save the slave address

Note:

It is also possible to display the tolerance limits when the instrument is operating in MIN, MAX or DELTA (TIR) mode.

4. Inputting tolerance limits

To input or modify the tolerance limits, t_{ol} → U_n mode should be selected, followed by a short press on **MODE** :

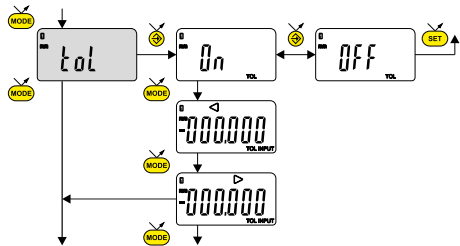

..... Input the lower tolerance limit ◀

..... Input the upper tolerance limit ▶

◀ next digit
 SET 0...9
 MODE save Tolerances

Note:

- For measuring internal dimensions, the red and yellow indicators can be switched over by reversing the order in which the tolerance limits are input (lower limit > upper limit).
- It is possible to input different tolerances on REF1 and REF2.

5. RS-485 Port configuration entry

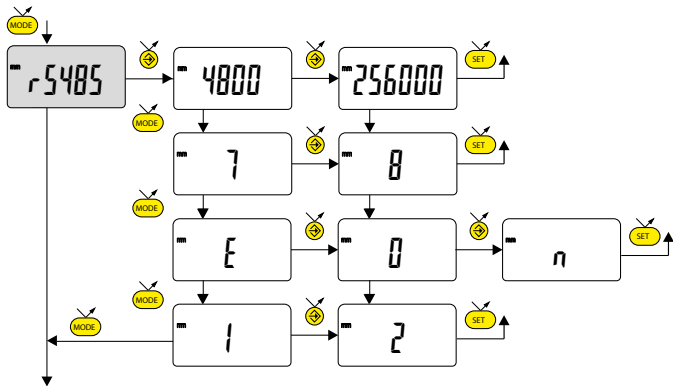

...RS-485 Port configuration

...Speed (bit/s)

...Data bits



...Parity

...Stop bits

6. Favourite key

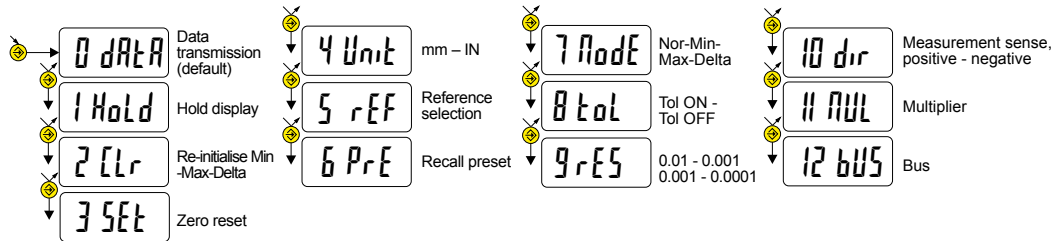
The «favourite» key gives direct access to a predefined function, and can be configured according to the needs of the user. In order to assign a function to the «favourite» key, give a prolonged press on , and then select the required function:



Validation of selection: By a prolonged press on  or a short press on  or 

Note: a function can also be assigned via RS232 using the command <FCT + Function No.>
example: Change of Unit = <FCT4>

7. Dynamic measurements

The PLC comparator executes 100 measurements / sec.

The maximum cosine error E_m of an eccentric cylinder, calculated over one rotation, is given in the graph below.

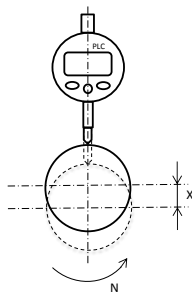
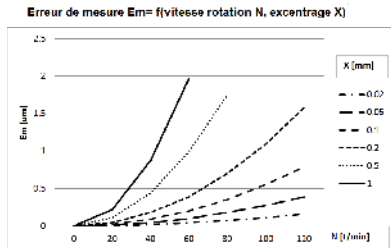

8. Re-initialising the instrument

The initial instrument settings can be restored at any time by a prolonged press (>4 sec) simultaneously on **MODE** and **SET** until the message *RESET* is displayed.

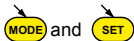

9. Personalising the instrument

Access to the functions of your instrument can be personalised, for more information see manufacturer's website (requires you to connect your instrument via a Proximity cable (RS or USB)).

Possibilities:

- De-activate or active the required functions
- Modify access to the advanced functions (direct access)

10. Connecting the instrument

The instrument can be connected to a peripheral via a Proximity cable (RS232 or USB), or via one of the RS485 buses.

10.1 RS-232 or USB connection

Measured values can be transmitted and the instrument driven using predefined commands (see chap. 12 for a list of the main retro-commands)

Note:

The result of the toleranced measurement is added to the position measurement (remote command?) in the form of a symbol.

= : the value is within the tolerances

< : The value is too small

> : The value is too large

10.2 RS-485 databus

The instrument can be connected to a field bus, via the link cable. See page 2 for connection of the cables.
The data exchange between a master and the slave PLC comparator(s) is defined by a protocol (MODBUS by default). See the table of transactions and variable addresses in the appendix.

Important note : The RS-485 lines are not galvanically isolated from the Power Supply. The reference Ground of the RS-485 Master must be tied to the Ground of the Power Supply

10.3 Field bus address configuration

The comparators do not have pre-defined addresses. They therefore do not reply to any bus request. Before being able to dialogue with a comparator it must be configured with a unique bus address. Configuration can be done either by SLA remote command, or by the SLA menu. Assigning a zero address causes deconfiguration of the comparator.

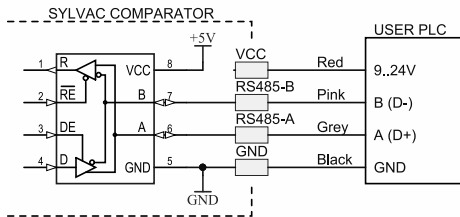

10.4 Digital outputs

3 digital outputs permit a decision on the current measurement (outside upper tolerance, outside lower tolerance, between the 2 tolerances). The activation delay for the outputs is a maximum of 25 ms after the measurement.

Type of outputs: Inactive -> open circuit. Active -> closed circuit to GND.

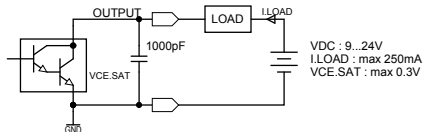

10.5 Digital inputs

1 digital input permits Preset/Zero recall.

1 digital input permits execution of the Favourite button function. Factory configuration: data transmission.

The duration of the input pulse is a minimum of 40 ms

Input type: Without supply (activation by closure to GND).

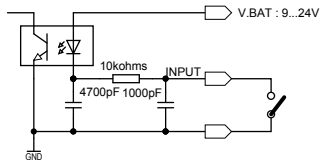

10.6. Automatic controller (PLC) link cable

Extra flexible cable. Wire cross-section: 0.05 mm² (26 x 0.05 mm Ø, AWG 30).

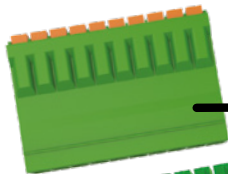

IFR 1,5/10 - ST 3,5
(110.052)

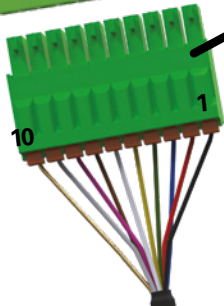

FMC 1,5/10 - ST 3,5
(110.051)

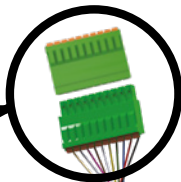

Phoenix contact



Wire colour	Signal name	Signal description
Black	GND (0 volt)	Supply (0 volt)
Red	VCC	Supply (9 ... 24 VDC) Note: supply from a USB port (+5 V) is only possible temporarily for manual or Proximity cable configuration
Blue	Output 3	Outside upper tolerance (Re-work)
Green	Output 2	Within tolerance limits (OK)
Yellow	Output 1	Outside lower tolerance (Scrap)
White	Input 2	Favourite button function execution
Brown	Input 1	Preset / Zero recall
Pink	RS-485-B (Data-)	Bus Link - B (half duplex)
Grey	RS-485-A (Data+)	Bus Link - A (half duplex)
Braid	PE	Shielding (earth protection)

If more than one digital indicator is connected to the PLC via the bus lines, all GND, all VCC, all RS-485-B (D-), all RS-485-A (D+) and all PE wires must be tied together.

11. List of the main commands

Selection and configuration

CHA+ / CHA-	Change measurement direction
FCT0 ...9...A...F	Assign «favourite» function
MM / IN	Change measurement unit
KEY0 / KEY1	Lock / unlock keypad
MUL [+/-]xxx.xxxx	Modify multiplication factor
PRE [+/-]xxx.xxx	Modify preset value
REF1 / REF2	Change active reference
STO1 / STO0	Activate / de-activate HOLD
TOL1 / TOL0	Activate / de-activate tolerances
LCAL dd.mm.yy	Modify last calibration date
NCAL dd.mm.yy	Modify next calibration date
NUM xxxxxxxxxxxx	Modify the instrument number
TOL +/-xxx.xxx +/-yyy.yyy	Inputting tolerance limits
RS232 baud, N, P, S [CRLF]	RS-232 port parameter selection
RS485 baud, N, P, S [CRLF]	RS-485 port parameter selection
BUS MODBUS/ASCII/ORBIT	Protocol selection
SLA aaa	MODBUS address selection
MIN /MAX /DEL /NOR	Selecting MIN, MAX, Delta, Normal mode
CLE	Re-initialisation of MIN, MAX or Delta
UNI1 / UNIO	Activate / de-activate change of units
OUT1 /OUT0	Activate / de-activate contin. data transmission
PRE ON / PRE OFF	Activate / de-activate Preset function
PRE	Recall Preset
SET	Zero reset
RES2 / RES3	Change of resolution

Interrogation

CHA?	Measurement sense?
FCT?	«favourite» function active?
UNI?	Measurement unit active?
KEY?	Keypad locked?
MUL?	Multiplication factor?
PRE?	Preset value?
REF?	Reference active?
STO?	Status of HOLD function?
TOL?	Current tolerance limit values?
LCAL?	Date of last calibration?
NCAL?	Date of next calibration?
NUM?	Instrument number ?
?	Current value (mode Tol, value followed by <=>)
RS232?	RS-232 port parameter?
RS485?	RS-485 port parameter?
BUS?	RS-485 bus protocol?
SLA?	MODBUS address?
MOD?	Active mode (MIN, MAX, Delta or Normal)?
SET?	Main instrument parameters?
ID?	Instrument identification code?
Maintenance functions	
OFF	Switch-off (wake up using a button or RS)
RST	Re-initialisation of the instrument
VER?	Version No. and date of firmware

12. Specifications

Measurement range:	12.5mm	25mm	
Max error (0.01mm scale):	10µm	10µm	(±1 digit)
Max error (0.001mm scale):	4µm	5µm	
Repeatability:		2µm	
Weight:	260g	265g	
Measurement force (standard):	0.65-0.9N	0.65-1.15N	
Max. speed of travel:		1.7m/s	
No. of measurements/ sec:		measurement: 100 mes/s	
Measurement unit:		metric/english (Inch)	
Maximum Preset (0.01mm scale):		±9999.99 mm / ±399.9995 IN	
Maximum Preset (0.001mm scale):		±999.999 mm / ±39.99995 IN	
Measurement system:		Sylvac inductive system (patented)	
Power:		9...24VDC	
Average consumption:		4mA (24VDC)	
Data output on Proximity :		RS232/USB compatible (default : 19'200, 7bits, Even, 2stop)	
Data bus		RS485 compatible, charge 1/256 (default : 128'000, 8bits, Even, 1stop)	
Digital data output:		Open Collector (NPN). 24 VDC/250 mA max, integrated polarity reversal and overvoltage protection (Freewheel Diode)	
Digital data input:		Max 24 VDC, impedance 10 kΩ, integrated polarity reversal protection	
Working temperature (storage):		+5 to +40°C (-10 to +60°C)	
Electromagnetic compatibility:		as per EN 61326-1	
IP rating (in accordance with IEC60529):		IP 67 / IP 54 (depending on model)	
Fixing and space envelope:		Ø8h6 (3/8"), interchangeable M2.5 (4-48-UNF) probe (as per DIN 878)	

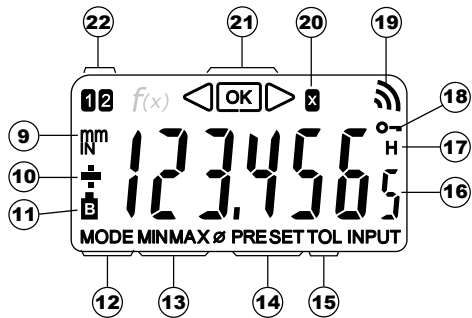
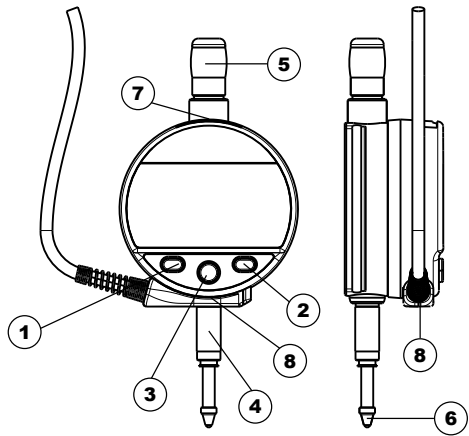
F

Description

1. Bouton MODE
2. Bouton SET
3. Bouton "Favoris"
4. Canon de fixation Ø8 ou 3/8"
5. Bonnette de relevage
6. Touche à bille Ø2/M2.5 ou 4-48-UNF
7. Logement pour câble Proximity
8. Connecteur PLC
9. Unité de mesure (mm/INCH)
10. Indicateur +/-
11. Tension d'alimentation trop faible
12. Indication du menu MODE
13. Mode MIN/MAX/DELTA
14. Mode Preset
15. Mode tolérance actif
16. Affichage 6 digits
17. Gel de la valeur de mesure
18. Verrouillage des boutons
19. Envoi de données
20. Facteur de multiplication
21. Indicateur des tolérances
22. Indicateur de la référence active



Introduction

Grâce à ses sorties digitales, le comparateur PLC fournit une information de tolérance de mesure performante à un automate externe (pièce bonne, à retravailler ou à rebuter). Deux entrées digitales configurables permettent de réinitialiser l'instrument pour une nouvelle mesure.

F

Les tolérances et autres paramètres de mesure peuvent être configurés directement avec les boutons de l'instrument. Une connexion USB/RS232 (Proximity) et une connexion par bus de terrain (MODBUS / ASCII / ORBIT) permettent un dialogue direct avec l'automate ou avec une autre application de collecte de données (SPC).

1. Les fonctionnalités de l'instrument

-  L'instrument possède 2 modes de travail : fonctions de base (avec accès direct) et fonctions avancées. En plus des fonctions de configuration, vous pouvez accéder à 2 référence de travail, au mode MIN, MAX et DELTA (TIR), à l'affichage des tolérances, ou à l'introduction d'un facteur de multiplication (voir chap. 3 et 4)
-  Le bouton «favori» permet d'attribuer un accès direct à la fonction principalement utilisée (voir chap. 6)
-  Le bouton «SET» permet d'attribuer une valeur de Preset, de réinitialiser le mode MIN/MAX, de quitter une sélection, et de gérer l'extinction de l'instrument.

- Personnalisation des fonctions

Vous avez la possibilité d'activer ou désactiver certaines fonctions de l'instrument par RS232 (voir chap. 9)

- Paramètres de transmission de données (port RS-232, valeurs par défaut)

4800Bds, 7 bits, parité paire, 2 stop bits

Paramètres de transmission de données (port RS-485, valeurs par défaut)

128'000Bds, 8 bits, parité paire, 1 stop bit

2. Fonctions de base

Chaque pression courte sur  permet un accès direct aux fonctions de base :

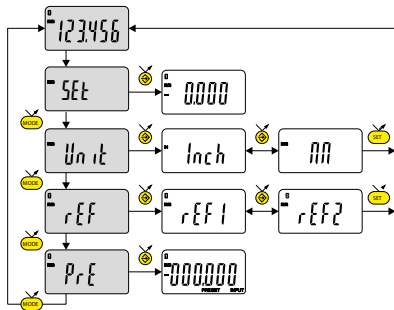



..... Mode normal : Mise à zéro

..... Sélection de l'unité (mm ou Inch)

..... Choix de la référence (REF1 ou REF2)

..... Introduction d'une valeur de Preset

 prochain digit  0...9  sauve le PRESET

Remarque : Il est possible d'attribuer une valeur de preset différente à chacune des 2 Références. De même, on peut attribuer des limites de tolérances différentes sur les références 1 et 2.

3. Fonctions avancées

Une pression longue (>2s) sur **MODE** permet d'accéder aux fonctions avancées. Puis, chaque pression courte sur **MODE** accède à la fonction souhaitée :

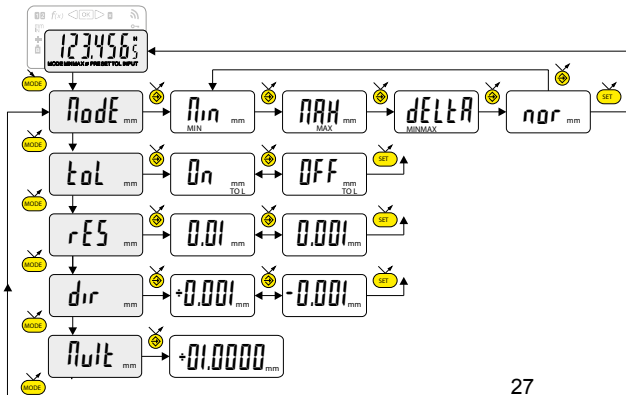

F

Mesure du MINIMUM, MAXIMUM et DELTA TIR (voir chap. 5)

Affichage des tolérances (introduction des limites de tolérances voir chap. 6)

Choix de la résolution 0.01 ↔ 0.001

Choix de la direction de mesure (sens positif ou négatif)

Introduction d'un facteur de multiplication autre que 1.0000

MODE Prochain digit **SET** 0...9 **MODE** sauve le facteur multiplicatif

..... suite

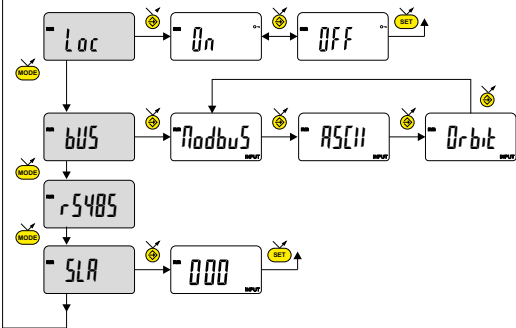



Blocage du clavier
Seule la touche favori  reste active

Sélection du protocole de communication

Configuration du Port RS-485 (voir chapitre 6)

Introduction de l'adresse Modbus esclave

 Prochain digit  0...9  sauve l'adresse esclave

Remarque :

Il est également possible d'afficher les limites de tolérance lorsque l'instrument travaille en mode MIN, MAX ou DELTA (TIR)

4. Introduction des limites de tolérances

Pour introduire ou modifier les limites de tolérances, il faut sélectionner le mode $t_{ol} \rightarrow U_n$, suivi d'une pression courte sur **MODE**

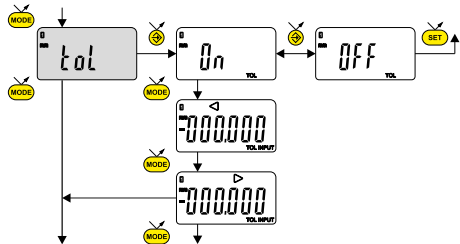

.....Introduire la limite de tolérance inférieure ◀

.....Introduire la limite de tolérance supérieure ▶

MODE prochain digit **SET** 0...9 **MODE** sauve la Tolérance

Remarque :

- Dans le cas de mesure de cotes d'intérieur, on peut croiser les indicateurs (rouge et jaune) en inversant l'ordre d'introduction des limites de tolérances (limite inférieure > limite supérieure).
- Il est possible d'introduire des limites de tolérances différentes sur les REF1 et REF2.

5. Introduction de la configuration du Port RS-485

F

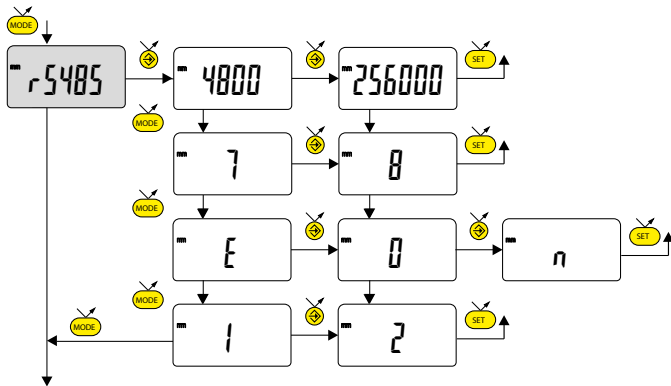

...Configuration du Port RS-485

...Vitesse (bit/s)

...Data bits

...Parité



...Stop bits

6. Touche favori

La touche « favori » permet l'accès direct à une fonction prédéfinie et peut être configurée selon les besoins de l'utilisateur.

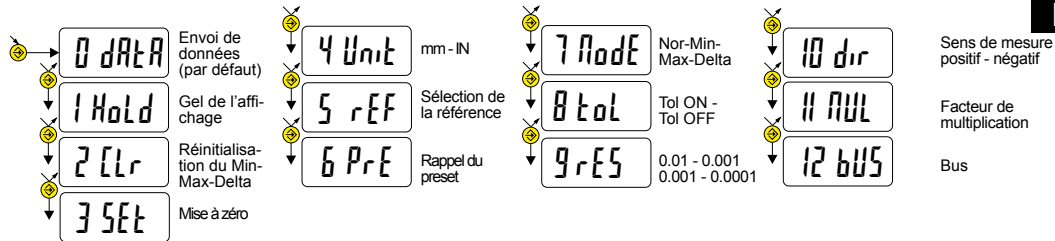
Pour attribuer une fonction à la touche « favori », effectuer une pression longue (>2s) sur , puis sélectionner la fonction souhaitée :



Validation de la sélection : Par une pression longue sur  ou une pression courte sur  ou 

Remarque : l'attribution de la fonction peut également se faire par RS 232, avec la commande <FCT + N° de fonction>
exemple : Changement d'unité = <FCT4>

7. Mesures dynamiques

Le comparateur PLC exécute 100 mesures / sec.

L'erreur de cosinus maximale E_m d'un cylindre excentré, calculée sur un tour, est donnée dans le graphique ci-dessous.

F

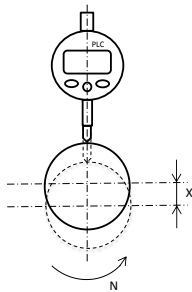
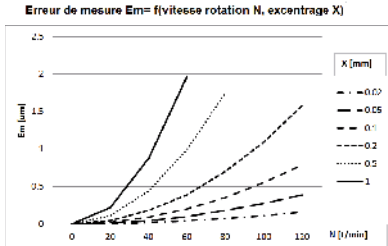

8. Réinitialisation de l'instrument

A tout moment, il est possible de restaurer les réglages initiaux de l'instrument, par une pression longue (>4s) simultanée

sur **MODE** et **SET** jusqu'à l'affichage du message *reset..*

9. Personnalisation de l'instrument

Il est possible de personnaliser l'accès aux fonctions de votre instrument, pour plus d'information voir site-web du fabricant (nécessite une connexion de votre instrument, via un câble Proximity (RS ou USB)

Possibilités :

- Désactiver ou activer les fonctions souhaitées
- Modifier l'accès aux fonctions avancées (mise en accès direct)

10. Connexions de l'instrument

L'instrument peut être connecté à un périphérique, via un câble Proximity (RS232 or USB), ou via un des bus RS485.

10.1. Connexions RS-232 ou USB

Possibilité de transmettre les valeurs mesurées, et piloter l'instrument à l'aide de rétro-commandes prédéfinies (liste des commandes principales, voir chap.12)

Remarque :

Le résultat de la mesure tolérancée est ajouté à la mesure de position (rétro-commande ?) sous forme d'un symbole.

= : la cote est dans les tolérances

< : La cote est trop petite

> : La cote est trop grande

10.2 Bus de données RS-485

L'instrument peut être connecté à un bus de terrain, via le câble de liaison. Voir en page 2 pour la connexion des câbles. L'échange de données entre un maître et le ou les comparateurs PLC esclaves est défini par un protocole (MODBUS par défaut). Voir la table des transactions et adresses des variables en annexe.

F

Note importante : La liaison RS-485 n'est pas galvaniquement isolée de l'alimentation. La masse de référence du Master RS-485 doit être reliée à la masse de l'alimentation

10.3 Configuration d'adresse pour Bus de terrain

D'usine les comparateurs n'ont pas d'adresse prédéfinie. Ils ne répondent donc à aucune requête bus. Avant de pouvoir dialoguer avec un comparateur, il faut le configurer avec une adresse bus unique. La configuration peut-être faite soit par la rétro commande SLA, soit par le menu SLA. L'attribution d'une adresse nulle provoque la déconfiguration du comparateur.

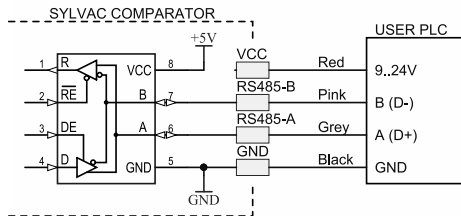

10.4 Sorties digitales

3 sorties digitales permettent la décision sur la mesure en cours (hors tolérance supérieure, hors tolérance inférieure, entre les 2 tolérances). Le délai d'activation des sorties est de maximum 25ms après la mesure.

Type de sorties : Inactives -> circuit ouvert. Actives -> circuit fermé contre GND.

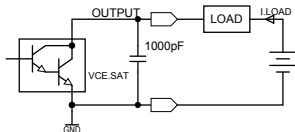

VDC : 9...24V
I.LOAD : max 250mA
VCE.SAT : max 0.3V

F

10.5 Entrées digitales

1 entrée digitale permet le rappel du Preset/Zéro.

1 entrée digitale permet l'exécution de la fonction du bouton Favori. Configuration usine: envoi de donnée.

La durée d'impulsion sur les entrées est de minimum 40ms

Type d'entrées : Sans alimentation (activation par fermeture contre GND).

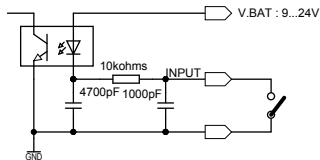

10.6. Câble de liaison avec automate (PLC)

Câble extra souple.
Section des fils :
0.05mm² (26x0.05mm
Ø, AWG 30).

F

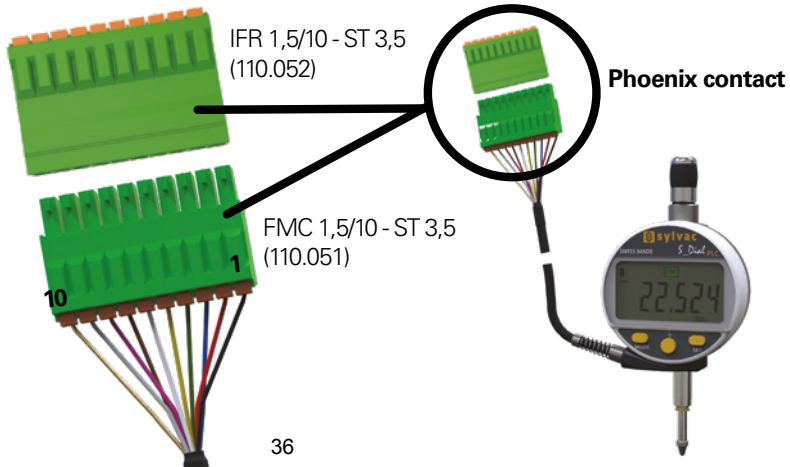

Couleur de fil	Nom du signal	Description du signal
Noir	GND (0 volt)	Alimentation (0 volt)
Rouge	VCC	Alimentation (9 ... 24VDC) Remarque: l'alimentation par un port USB (+5V) n'est possible que de manière temporaire pour une configuration manuelle de l'instrument ou par câble Proximity
Bleu	Sortie 3	Hors tolérance supérieure (Re-travail)
Vert	Sortie 2	Dans les limites de tolérance (OK)
Jaune	Sortie 1	Hors tolérance inférieure (Rebut)
Blanc	Entrée 2	Exécution de la fonction du bouton Favori.
Brun	Entrée 1	Rappel du Preset / Zéro
Rose	RS-485-B (Data-)	Liaison Bus -B (half duplex)
Gris	RS-485-A (Data+)	Liaison Bus -A (half duplex)
Tresse	PE	Blindage (terre de protection)

Si plus d'un comparateur est connecté au PLC à travers les lignes du bus, les fils GND, VCC, RS-485-B (D-), RS-485-A (D+) et tous les fils de terre (PE) doivent être reliés ensemble

11. Liste des commandes principales

Sélection et configuration

CHA+ / CHA-	Changement direction de mesure
FCT0 ...9...A...F	Attribution fonction «favori»
MM / IN	Changement unité de mesure
KEY0 / KEY1	Active / désactive le blocage clavier
MUL [+/-]xxx.xxxx	Modification facteur de multiplication
PRE [+/-]xxx.xxx	Modification valeur de preset
REF1 / REF2	Changement de la référence active
STO1 / STO0	Active / désactive le HOLD
TOL1 / TOL0	Active / désactive les tolérances
LCAL dd.mm.yy	Modifie date dernière calibration
NCAL dd.mm.yy	Modifie date prochaine calibration
NUM xxxxxxxxxx	Modifie le numéro de l'instrument
TOL +/-xxx.xxx +/-yyy.yyy	Introduction des limites de tolérances
RS232 baud, N, P, S [CRLF]	Sélection paramètre port RS-232
RS485 baud, N, P, S [CRLF]	Sélection paramètre port RS-485
BUS MODBUS/ASCII/ORBIT	Sélection de protocole
SLA aaa	Sélection adresse MODBUS
Sélection mode MIN, MAX, Delta, Normal	
CLE	Réinitialisation du MIN, MAX ou Delta
UNI1 / UNIO	Active / désactive le changement d'unité
OUT1 / OUT0	Active / désact. transmission données en continu
PRE ON / PRE OFF	Active / désact. la fonction Preset
PRE	Rappel du Preset
SET	Mise à zéro
RES2 / RES3	Changement résolution

Interrogation

CHA?	Sens de mesure?
FCT?	Fonction «favori» active?
UNI?	Unité de mesure active?
KEY?	Blocage clavier?
MUL?	Facteur de multiplication?
PRE?	Valeur de preset?
REF?	Référence active?
STO?	Etat fonction HOLD?
TOL?	Valeur des limites de tol actuelles?
LCAL?	Date dernière calibration?
NCAL?	Date prochaine calibration?
NUM?	Numéro de l'instrument?
?	Valeur actuelle? (mode Tol, valeur suivie de <=>)
RS232?	Paramètre port RS-232?
RS485?	Paramètre port RS-485?
BUS?	Protocole de bus RS-485?
SLA?	Adresse MODBUS?MIN / MAX / DEL / NOR
MOD?	Mode actif (MIN, MAX, Delta ou Normal)?
SET?	Paramètres principaux de l'instrument?
ID?	Code d'identification de l'instrument?

Fonctions de maintenance

OFF	Extinct. complète (réveil par bouton ou RS)
RST	Réinitialisation de l'instrument
VER?	Révision et date du firmware

12. Spécifications

Etendue de mesure:	12.5mm	25mm	
Erreur max (échelon 0.01mm):	10µm	10µm	(±1 digit)
Erreur max (échelon 0.001mm):	4µm	5µm	
Répétabilité:		2µm	
Poids:	260g	265g	
Force de mesure (standard):	0.65-0.9N	0.65-1.15N	
Vitesse max. de déplacement:	1.7m/s		
Nbre de mesure par seconde:	mesure: 100 mes/s		
Unité de mesure:	métrique/anglaise (Inch)		
Preset maximum (échelon 0.01mm):	±9999.99 mm / ±399.9995 IN		
Preset maximum (échelon 0.001mm):	±999.999 mm / ±39.99995 IN		
Système de mesure:	Sylvac inductive system (breveté)		
Alimentation:	9...24VDC		
Consommation moyenne	4mA (sous 24 VDC)		
Sortie de données sur Proximity :	compatible RS232/USB (défaut : 19'200, 7bits, Even, 2stop)		
Bus de données :	compatible RS485, charge 1/256 (défaut : 128'000, 8bits, Even, 1stop)		
Sorties digitales	Collecteur Ouvert (NPN). Max 24VDC/250mA, protection contre les inversions de polarité et les surtensions intégrée (Diode Roue-libre)		
Entrées digitales	Max 24VDC, impédance 10kΩ, protection contre les inversions de polarité intégrée		
Température de travail (stockage):	+5 à +40°C (-10 à +60°C)		
Compatibilité électromagnétique:	selon EN 61326-1		
Spécification IP (selon IEC60529):	IP 67 / IP 54 (selon modèle)		
Fixation et encombrement:	fixation Ø8h6 (3/8"), touche de mesure interchangeable M2.5 (4-48-UNF) (selon DIN 878)		

F

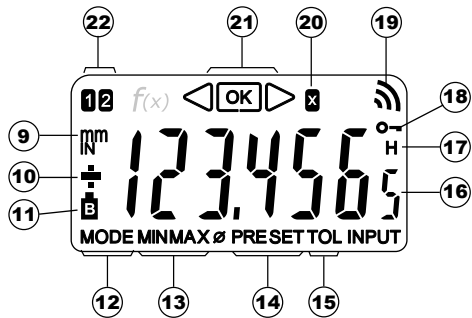
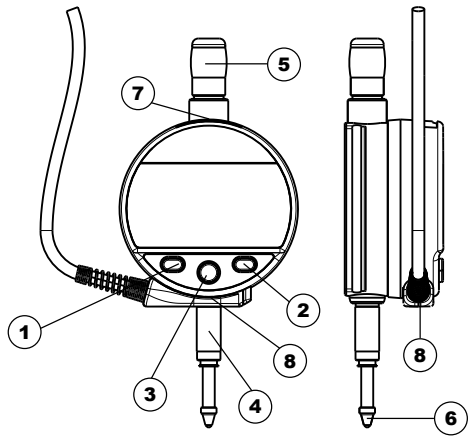
D

Beschreibung

1. MODE-Taste
2. SET-Taste
3. Favoriten-Taste
4. Einspannschaft Ø8 oder 3/8"
5. Abhebekapsel
6. Kugeltaster Ø2/M2.5 oder 4-48-UNF
7. Buchse für Proximity Kabel
8. PLC Steckverbinder
9. Masseinheit (mm/INCH)
10. +/- Anzeige
11. Zu geringe Versorgungsspannung
12. Anzeige des Menüs Mode
13. MIN/MAX/DELTA-Modus
14. Preset-Modus
15. Toleranz-Modus
16. Anzeige von 6 Ziffern
17. Festhalten des Messwerts
18. Tastatursperre
19. Datenübertragung
20. Multiplikationsfaktor
21. Toleranzanzeiger
22. Aktive Referenz



Einführung

Mit Hilfe der digitalen Ausgänge kann der PLC-Komparator eine Toleranz Informationen über die Messung an eine externe Steuerung senden (Werkstück in Ordnung, Neubearbeitung oder Ausschuss). Dank der zwei konfigurierbaren digitalen Eingänge kann das Instrument für eine neue Messung zurückgesetzt werden.

Die Toleranzen und andere Messdaten können direkt über die Tasten des Messinstruments eingegeben werden.

Ein USB/RS232-Anschluss (Proximity) und ein Feldbus-Anschluss (MODBUS / ASCII / ORBIT) erlauben eine direkte Verbindung zur Steuerung oder zu einer anderen Anwendung zur Datenerfassung (SPC).

1. Funktionalitäten des Instruments:

-  Das Instrument verfügt über zwei Betriebsarten: Basisfunktionen (mit direktem Zugang) und fortgeschrittene Funktionen. Neben den Konfigurationsfunktionen hat man Zugriff auf 2 Arbeitsreferenzen, den Modi MIN, MAX und DELTA (TIR), auf die Toleranzanzeige oder auf die Eingabe eines anderen Multiplikationsfaktors als 1:1. (siehe Kap. 3 und 4).
-  Mit der Taste „Favoriten“ kann man der hauptsächlich verwendeten Funktion einen direkten Zugriff zuzuweisen (siehe Kap. 6)
-  Ermöglicht die Zuweisung eines Presetwertes, die Reinitialisierung der Modi MIN/MAX, die Quittierung einer Auswahl und die Steuerung des Ausschaltens des Instruments. Der SIS-Modus ermöglicht standardmässig das automatische Ausschalten ohne Verlust der Anfangseinstellung (siehe Kap. 7).

- Personalisierung der Funktionen

Es ist möglich, einige Funktionen des Instruments über R232 zu aktivieren oder zu deaktivieren (siehe Kap.9)-

Parameter für Datenübertragung (RS232-Port, voreingestellte Werte)

4800Bds, 7 bits, gerade Parität, 2 stop bits

Parameter für Datenübertragung (R485-Port, voreingestellte Werte)

128'000Bds, 8 bits, gerade Parität, 1 stop bit

2. Grundfunktionen

Jede kurze Betätigung von  ermöglicht einen direkten Zugriff auf die Grundfunktionen:

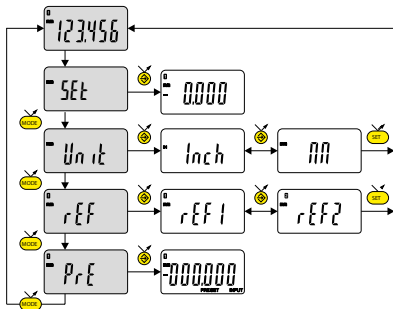



.....Normaler Modus: Nulleinstellung

.....Wahl der Einheit (mm oder Inch)

.....Wahl der Referenz (REF1 oder REF2)

.....Eingabe des Presetwertes

 nächste Ziffer  0...9  PRESET speichern

Anmerkung: Es ist möglich, jeder der beiden Referenzen einen unterschiedlichen Presetwert zuzuordnen. Ebenso kann man den Referenzen 1 und 2 unterschiedliche Toleranzgrenzen zuordnen.

3. Fortgeschrittene Funktionen

Eine lange Betätigung (>2s) von **MODE** ermöglicht es, auf die fortgeschrittenen Funktionen zuzugreifen. Anschließend führt jede kurze Betätigung von **MODE** zur gewünschten Funktion:

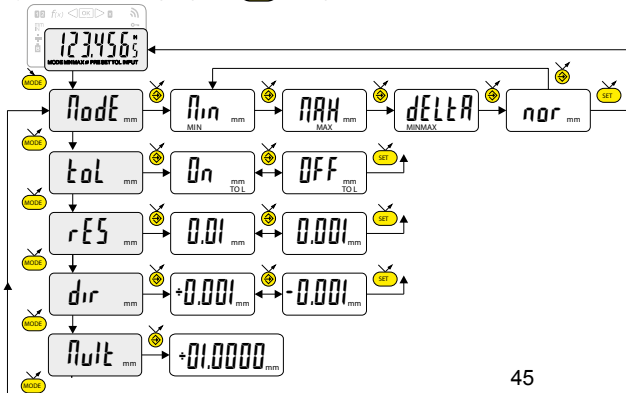

MIN MAX measurement
DELTA (TIR)

Tolerance display
(inputting tolerance limits, see chap. 5)

Auflösung 0.01 ↔ 0.001

Wahl der Messrichtung
(Positive oder negative Richtung)

Eingabe eines Multiplikators, außer 1,0000

 Nächste Ziffer
  0...9
  Multiplikator speichern

D

..... Forsetzung

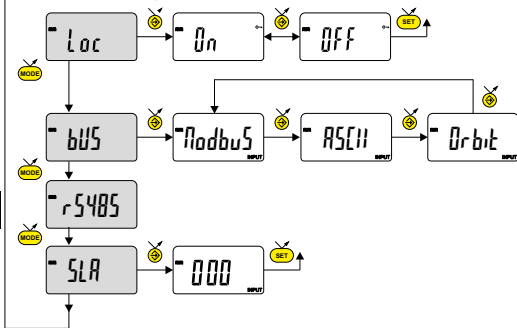



Tastensperre
nur die Favoritentaste  bleibt aktiv

Auswahl des Kommunikationsprotokolls

Konfiguration des RS485-Ports (siehe Kapitel 6)

Eingabe der Adresse des Modbus-Slaves

 Nächste Ziffer  0...9  Slave-Adresse speichern

Anmerkung:

Es ist auch möglich, die Toleranzwerte anzuzeigen, wenn das Instrument in der Betriebsart MIN, MAX oder DELTA (TIR) arbeitet.

4. Eingabe der Toleranzgrenzen

Um die Toleranzgrenzen einzugeben oder zu ändern, zu ändern Betriebsart t_{ol} \rightarrow U_n wählen und dann kurz auf drücken **MODE**:

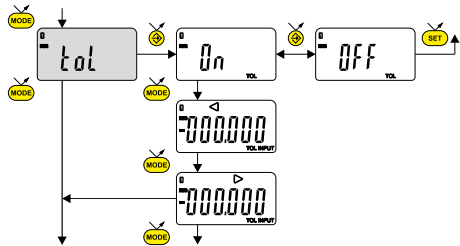

.....Die untere Toleranzgrenze eingeben ◀

.....Die obere Toleranzgrenze eingeben ▶

◀ nächste Ziffer SET 0...9 MODE Toleranz speichern

Anmerkung:

- Im Fall einer Messung der inneren Abmaße kann man die Anzeiger (rot und gelb) kreuzen, indem man die Eingabereihenfolge der Toleranzgrenzen umkehrt (untere Grenze > obere Grenze).
- Es ist möglich, verschiedene Toleranzwerte bei REF1 und REF2 einzugeben.

5. Eingabe der Konfiguration des RS485-Ports

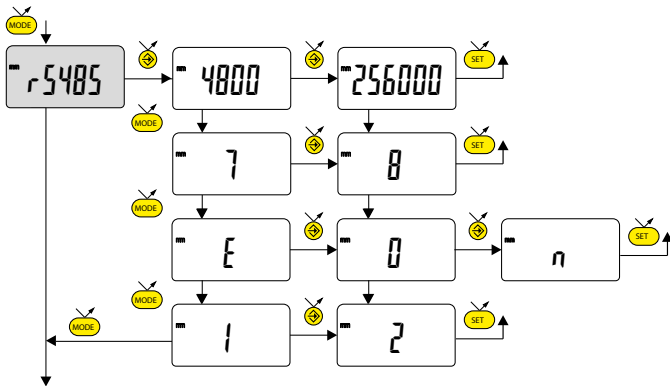

...Konfiguration des RS485-Ports

...Geschwindigkeit (bit/s)

...Data bits

...Parität



...Stop bits

D

6. Favoriten-Taste

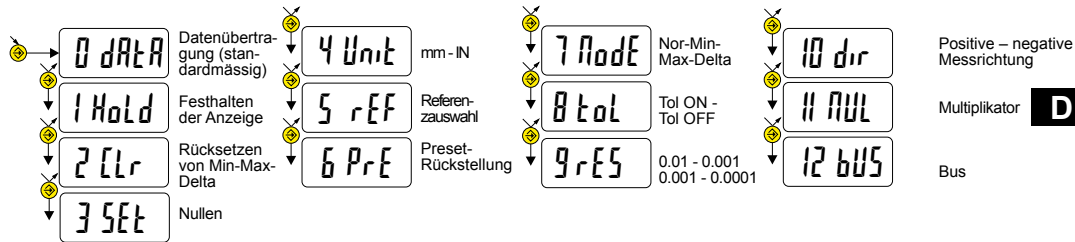
Die „Favoriten-Taste“ ermöglicht den direkten Zugriff auf eine zuvor bestimmte Funktion und kann entsprechend der Bedürfnisse des Nutzers konfiguriert werden. Um der „Favoriten-Taste“ eine Funktion zuzuordnen, muss man lange auf  drücken und dann die gewünschte Funktion wählen:



Bestätigung der Auswahl: Durch langes Drücken von  oder kurzes Drücken von  oder 

Anmerkung: Die Zuordnung der Funktion kann auch durch RS 232 erfolgen, mit der Steuerung <FCT + Funktions-Nr.>
Beispiel: Masseinheit = <FCT4>

7. Dynamische Messungen

Der PLC-Komparator führt 100 Messungen pro Sekunde durch. Der maximale Kosinusfehler E_m eines exzentrischen Zylinders, der bei einer Drehung berechnet wird, ist in der folgenden Grafik dargestellt.

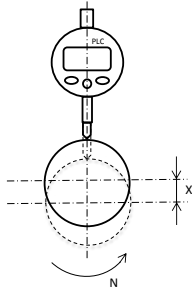
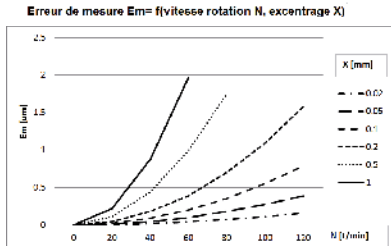

8. Rücksetzen des Instruments

Man kann die Werkseinstellungen des Instruments jederzeit mit einem langen (>4s), gleichzeitigen Drücken bis zur Anzeige der Meldung $rE5Et$ auf **MODE** und **SET** wiederherstellen.

Das Instrument behält jedoch die Konfigurationseinstellungen (Einheit und Auflösung), sowie die letzte aktive Referenz.

9. Personalisierung des Instruments

Es ist möglich, den Zugriff auf die Funktionen Ihres Instruments mit Hilfe der kostenlosen Software zu personalisieren. Weitere Informationen finden Sie auf der Webseite des Herstellers (erfordert den Anschluss Ihres Instruments mit einem Proximity-Kabel (RS oder USB).

Möglichkeiten:

- die Deaktivierung oder Aktivierung der erwünschten Funktionen
- die Änderung des Zugriffs auf die fortgeschrittenen Funktionen (Schaffung eines direkten Zugriffs)

10. Anschluss des Instruments

Das Instrument kann mit einem Proximity-Kabel (RS oder USB) oder Via einem RS485-Bus an ein Peripheriegerät angeschlossen werden.

10.1. Anschluss RS-232 oder USB

Man kann die gemessenen Werte übertragen und das Instrument mit Hilfe von bestimmten Befehlen steuern. Liste der wesentlichen Steuerbefehle, siehe Kap. 12.

Anmerkung:

Das Ergebnis der Toleranzmessung wird zur Positionsmessung (Remote-Befehl?) in Form eines Symbols hinzugefügt.

= : das Maß liegt innerhalb der Toleranzen

< : das Maß ist zu klein

> : das Maß ist zu groß

10.2 Datenbus RS485

Das Instrument kann mit dem Verbindungskabel an einen Feldbus angeschlossen werden. Informationen zum Anschluss der Kabel finden Sie auf Seite 2.

Der Datenaustausch zwischen einem Master und den PLC-Komparator-Slaves wird über ein Protokoll definiert (Standard: MODBUS). Siehe Tabelle „Transaktionen und Adressen der Variablen“ im Anhang.

Wichtiger Hinweis: Die RS-485 Verbindung ist galvanisch nicht von der Stromversorgung getrennt. Die Bezugsmasse des Master RS-485 müssen an die Stromversorgungs-masse verbunden werden

D 10.3 Konfiguration der Feldbus-Adresse

Die Komparatoren haben ab Werk keine vordefinierte Adresse. Sie antworten demnach auf keine Bus-Anfrage. Um die Kommunikation mit einem Komparator zu ermöglichen, muss diesem zunächst eine eindeutige Busadresse zugewiesen werden. Die Konfiguration kann über den Remote-Befehl SLA oder das SLA-Menü erfolgen. Die Zuweisung einer Nulladresse bewirkt die Dekonfiguration des Komparators.

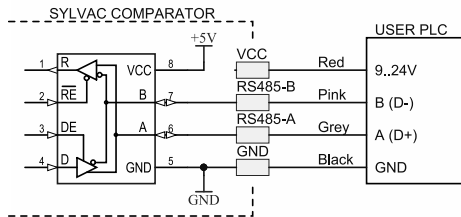

10.4 Digitale Ausgänge

Mit Hilfe von 3 digitalen Ausgängen kann über die laufende Messung entschieden werden (außerhalb der oberen Toleranz, außerhalb der unteren Toleranz, innerhalb der beiden Toleranzen). Die Aktivierungsverzögerung der Ausgänge beträgt höchstens 25 ms nach der Messung. Ausgangsart: Inaktiv -> offener Kreis. Aktiv -> geschlossener Kreis gegen GND.

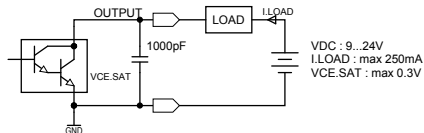

10.5 Digitale Eingänge

1 digitaler Eingang ermöglicht die Rücksetzung auf die Voreinstellung bzw. auf Null.

1 digitaler Eingang ermöglicht die Ausführung der Favoritentastenfunktion. Werkseinstellung: Datenübertragung.

Die Impulsdauer an den Eingängen beträgt mindestens 40 ms

Eingangsart: Ohne Strom (Aktivierung durch Schließen gegen GND).

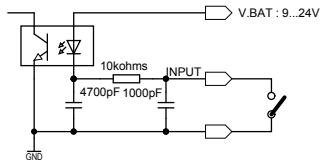

10.6. Verbindungskabel zur Steuerung (PLC)

Extra biegsames Kabel.
Drahtstärke: 0,05 mm²
(26 x 0,05 mm Ø, AWG
30).

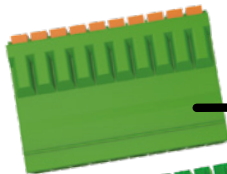

IFR 1,5/10 - ST 3,5
(110.052)

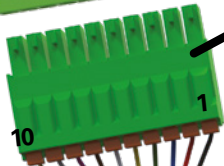

FMC 1,5/10 - ST 3,5
(110.051)

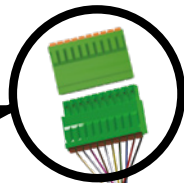

Phoenix contact



D

Drahtfarbe	Signalbezeichnung	Signalbeschreibung
Schwarz	GND (0 volt)	Stromversorgung (0 volt)
Rot	VCC	Stromversorgung (9 ... 24VDC) Hinweis: Die Stromversorgung am USB-Port (+5 V) ist für eine manuelle Konfiguration oder eine Konfiguration des Instruments über das Proximity-Kabel nur zeitweilig möglich
Blau	Ausgang 3	Außerhalb der oberen Toleranz (Neubearbeitung)
Grün	Ausgang 2	Innerhalb der Toleranzen (OK)
Gelb	Ausgang 1	Außerhalb der unteren Toleranz (Ausschuss)
Weiss	Eingang 2	Ausführung der Favoritentastenfunktion.
Braun	Eingang 1	Rückstellung auf die Voreinstellung bzw. auf Null
Pink	RS-485-B (Data-)	Bus-Verbindung – B (Halbduplex)
Grau	RS-485-A (Data+)	Bus-Verbindung – A (Halbduplex)
Geflochten	PE	Abschirmung (Schutzleiter)

Falls mehr als eine Messuhr über ihren Bus an einem PLC angeschlossen wird, müssen alle Linien GND, VCC, RS-485-B (D-), RS-485-A (D+) und alle Erdungen (PE) miteinander verbunden werden

11. Liste der wesentlichen Steuerbefehle

Auswahl un Konfiguration

CHA+ / CHA-	Wechsel der Messrichtung
FCT0 ...9...A...F	Zuordnung der Funktion „Favorit“
MM / IN	Wechsel der Masseinheit
KEY0 / KEY1	Aktiviert / Deaktiviert die Tastatursperre
MUL [+/-]xxx.xxxx	Änderung des Multiplikationsfaktors
PRE [+/-]xxx.xxx	Änderung des Presetwertes
REF1 / REF2	Wechsel der aktiven Referenz
STO1 / STO0	Aktiviert / Deaktiviert den HOLD
TOL1 / TOL0	Aktiviert / Deaktiviert die Toleranzen
LCAL dd.mm.yy	Ändert das Datum der letzten Kalibrierung
NCAL dd.mm.yy	Ändert das Datum der nächsten Kalibrierung
NUM xxxxxxxxxxxx	Instrumentennummer ändern
TOL +/-xxx.xxx +/-yyy.yyy	Eingabe Toleranzen
RS232 baud, N, P, S [CRLF]	Auswahl des Parameters RS232-Port
RS485 baud, N, P, S [CRLF]	Auswahl des Parameters RS485-Port
BUS MODBUS/ASCII/ORBIT	Auswahl des Protokolls
SLA aaa	Auswahl der MODBUS-Adresse
MIN / MAX / DEL / NOR	Auswahl des Modus MIN, MAX, Delta, Normal
CLE	Rücksetzen von Min, Max oder Delta
UNI1 / UNIO	Aktiviert / Deaktiviert den Einheitswechsel
OUT1 /OUT0	Aktiviert / Deaktiviert die kontinuierliche Datenübertragung
PRE ON / PRE OFF	Aktiviert /Deaktiviert die Presetfunktion
PRE	Preset-Rückstellung
SET	Nullen
RES2 / RES3	Ändern des Ziffernschrittwerts

Abfragen

CHA?	Messrichtung?
FCT?	Funktion „Favorit“ aktiv?
UNI?	Masseinheit aktiv
KEY?	Tastatursperre?
MUL?	Multiplikationsfaktor?
PRE?	Presetwert?
REF?	Aktive Referenz?
STO?	HOLD Funktionsstatus?
TOL?	Wert der aktuellen Tol.-Grenzen?
LCAL?	Datum der letzten Kalibrierung?
NCAL?	Datum der nächsten Kalibrierung?
NUM?	Instrumentennummer?
?	Aktueller Wert (Tol.-Modus, Wert gefolgt von <=>)
RS232?	Parameter RS232-Port?
RS485?	Parameter RS485-Port?
BUS?	Protokoll des RS485-Bus?
SLA?	MODBUS-Adresse?
MOD?	Aktiver Modus (MIN, MAX, Delta oder Normal)?
SET?	Hauptparameter des Instruments?
ID?	Identifizierungscode des Instruments?

Wartungsfunktionen

OFF	Vollständ. Ausschalten (Neuaktivierung mit Knopf oder RS)
RST	Rücksetzen des Instruments
VER?	Revision und Datum der Firmware

12. Spezifizierungen

Messbereich:	12.5mm	25mm	
Fehlergrenze (Stufe 0.01mm):	10µm	10µm	(±1 digit)
Fehlergrenze (Stufe 0.001mm):	4µm	5µm	
Wiederholbarkeit:		2µm	
Gewicht:	260g	265g	
Messkraft (Standard):	0.65-0.9N	0.65-1.15N	
Maximale Bewegungsgeschwindigkeit:		1.7m/s	
Anzahl der Messungen pro Sekunde:		Messung: 100 Mess/s	
Masseinheit:		mm / Inch	
Maximum Preset (Stufe 0.01mm):		±9999.99 mm / ±399.9995 IN	
Maximum Preset (Stufe 0.001mm):		±999.999 mm / ±39.99995 IN	
Messsystem:		Sylvac inductive system (patentiert)	
Versorgung:		9...24VDC	
Durchschnittlicher Verbrauch:		4mA (24VDC)	
Datenausgang an Proximity:		kompatibel mit RS232/USB (Standard: 19 200, 7 bit, Even, 2 stop)	
Datenbus		kompatibel mit RS485, Last 1/256 (Standard: 128 000, 8 bits, Even, 1 stop)	
Digitale Ausgänge:		Kollektor offen (NPN). Max. 24 VDC/250 mA, integrierter Schutz gegen Polaritätswechsel und Überspannung (Freilaufdiode)	
Digitale Eingänge ::		Max. 24 VDC, Impedanz 10 kΩ, integrierter Schutz gegen Polaritätswechsel	
Arbeitstemperatur (Lagerung):		+5 bis +40°C (-10 bis +60°C)	
Elektromagnetische Verträglichkeit:		gemäß EN 61326-1	
IP Spezifikation (gemäß IEC60529):		IP 67 / IP 54 (je nach Modell)	
Befestigung und Platzbedarf:		Ø8h6 (3/8") Befestigung, austauschbarer M2.5 (4-48-UNF) Messeinsatz (gemäß DIN 878)	

A. Annexe MODBUS Protocol

Default RS485 configuration for Modbus protocol :

128'000bauds

8 bits

Even parity

1 stop

D

A.1 Modbus transactions

The master issues a Query Modbus frame on the bus. The addressed slave answers (except for broadcast requests) with a Response Modbus frame. The slave answer can be a correct answer or an Exception in case of error.

For better data throughput, Sylvac modules always use the RTU transmission mode. For more details on Modbus protocol, refer to the MODBUS Application Protocol.

http://www.modbus.org/docs/PI_MBUS_300.pdf

A.2 Frame description

Query frame format

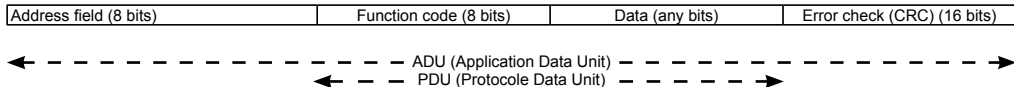

Where :

Address field : The slave number (1...247, 0=reserved for broadcast)

Function code : See following table for supported functions

Error check (CRC) : Based on polynome $1 + X^2 + X^{15} + X^{16}$

Normal response frame format

Function code (8 bits)	Data (any bits)	Error check (CRC) (16 bits)
------------------------	-----------------	-----------------------------

Exception response frame format

Function code + 0x80 (8 bits)	Exception code (8 bits)	Error check (CRC) (16 bits)
-------------------------------	-------------------------	-----------------------------

Table of supported modbus functions

Function code	Description	PDU request format	PDU answer format
01	Read n bits	0x01 aaaa nnnn	0x01 bb ll
02		0x02 aaaa nnnn	0x02 bb ll
03	Read n registers	0x03 aaaa nnnn	0x03 bb ll
04		0x04 aaaa nnnn	0x04 bb ll
05	Write 1 bit	0x05 aaaa yy00	0x05 aaaa yy00
06	Write 1 register	0x06 aaaa vvvv	0x06 aaaa vvvv
07	Read fast status byte	0x07	0x07 ff The bit 0 set in ff indicates a new available position
08 00	Echo diagnostic	0x08 0x00 llll	0x08 0x00 llll
08 01	Restart communication (vvvv = 0xFF00 to clear the event counter of function 11, 0x0000 to keep it)	0x08 0x01 vvvv	0x08 0x01 vvvv

Function code	Description	PDU request format	PDU answer format
08 02	Read diagnostic register	0x08 0x02 0x0000	0x08 0x02 vvvv Bits of vvvv : Bit 0 : Rs485 hardware error Bit 1 : Rs485 software error Bit 2 : Instrument flash error Bit 3 : Slave configuration error
08 04	Listen only	0x08 0x04 0x0000	(No response)
08 10	Clears all diagnostic registers	0x08 0x0A 0x0000	0x08 0x0A 0x0000
08 11	Reads bus messages counter	0x08 0x0B 0x0000	0x08 0x0B nnnn
08 12	Reads invalid bus messages counter	0x08 0x0aC 0x0000	0x08 0x0C nnnn
08 13	Reads exceptions counter	0x08 0x0D 0x0000	0x08 0x0D nnnn
08 14	Reads slave addressed messages counter	0x08 0x0E 0x0000	0x08 0x0E nnnn
08 15	Reads broadcast messages counter	0x08 0x0F 0x00a00	0x08 0x0F nnnn
08 16	Reads NAK messages counter	0x08 0x10 0x0000	0x08 0x10 nnnn

Function code	Description	PDU request format	PDU answer format
08 17	Reads Slave busy counter	0x08 0x11 0x0000	0x08 0x11 nnnn
08 18	Reads bus overrun counter	0x08 0x12 0x0000	0x08 0x12 nnnn
08 20	Clears overrun counter	0x08 0x14 0x0000	0x08 0x14 0x0000
11	Reads event counter	0x0B	0x0B nnnn
15	Write n bits	0x0F aaaa nnnn bb ll	0x0F aaaa nnnn
16	Write n registers	0x10 aaaa nnnn bb llll	0x10 aaaa nnnn
17	Reads module identification	0x11	0x11 nn ID[] R/S

With

aaaa	Address	nn	Quantity of data (1 byte)
bb	Number of bytes	nnnn	Quantity of data (2 bytes)
ff	Fast byte	yy00	Bit state
ll	Bytes list	vvvv	Word value
llll	Registers list	ID[]	Identification : PM289.950# followed by the slave number (1 byte binary)
R/S	Run/Stop byte (0xff = Run, 0x00 = Stop))		

A.3. Adresses of the Modbus variables

The access to the addressed variables is possible through the functions 1..6, 15, 16. Function 7 allows a fast access to know if there is a new data sensor position.

Note: In the following description, all addresses of variables are given in decimal, not in hexadecimal.

Two independent memory areas containing 10,000 addresses are overwritten for bit access or word access. Access to an address not defined by Sylvac returns an error. All the addresses are between 0 and 9999.

Access to a variable may be:

- Read and write (R/W)
- Read only (RO)
- Write only (WO)
- R/W* indicates that a variable can be read but always returns 0.
- RO Δ indicates that the value can only be read once (reading causes the variable to be reset to zero)

Access to a sensor position variable while the sensor is in error returns the code -1 (not a number, NAN in the usual IEEE754 float format).

A.3.1 Address of the Modbus bit variables (function codes 01, 02, 05, 15)

Function	Address (decimal)	Nb of bits	Access type	Comment
Freezes the measurement	0000	1	R/W	0 to release
Min., max. and delta reset to zero	0001	1	R/W*	
Preset recall	0002	1	R/W*	
Preset recall on min value	0003	1	R/W*	
Preset recall on max value	0004	1	R/W*	
Measurement in inches	0065	1	R/W	0 for measurement in mm
Negative measurement direction	0067	1	R/W	0 for positive direction

Function	Address (decimal)	Nb of bits	Access type	Comment
Activated tolerances	0068	1	R/W	0 for disabled tolerances
Active diameter mode	0070	1	R/W	0 for inactive diameter mode
Low resolution	0071	1	R/W	0 for low resolution
2nd reference	0075	1	R/W	0 for 1st reference
Mult Factor activation	0076	1	R/W	0 for inactive (forced to 1.0)
Keys locked	0077	1	R/W	0 to lock the Keys
Auto OFF	0078	1	R/W	0 to disable Auto OFF
User reset	9024	1	R/W*	
Factory reset	9025	1	R/W*	
Configuration procedure starts (see Modbus address configuration)	9536	1	R/W	0 to end the configuration procedure

A.3.2 Adresses of the Modbus word variables (function codes 03, 04, 06, 16)

F32 means a Float value coded according to IEEE754.

Function	Address (decimal)	Nb of bits	Access type	Comment
Instrument position	0002	32	RO	In 1/10 th of μm
Information bits 1	0004	8+8	8RW+8RO	Bit 0: Frozen measurement Bit 1: Reset min/max/delta to 0 Bit 2: Preset recall Other bits reserved for future use
Information bits 2	0005	16	RO	Bit 0: Inch unit Bit 1: Negative direction Bit 2: - Bit 3: resolution Bit 4: Bit 5: - Bit 6: Min. mode Bit 7: Max. mode Bit 8: Delta mode Bit 9: Frozen measurement Bit 10: Tolerances Other bits reserved for future use

Function	Address (decimal)	Nb of bits	Access type	Comment
Formatted position	0006	F32	RO	Formatted position (see below)
Formatted min. value	0008	F32	RO	Formatted position (see below)
Formatted max. value	0010	F32	RO	Formatted position (see below)
Formatted delta value	0012	F32	RO	Formatted position (see below)
Access to bits 0000-0031	0056	2x16	RW	See corresponding bits
Formatted Preset value	0060	F32	RW	Formatted position (see below)
Nominal value for tolerance, formatted.	0062	F32	RW	Formatted position (see below)
Formatted upper tolerance	0064	F32	RW	Formatted position (see below)
Formatted lower tolerance	0066	F32	RW	Formatted position (see below)

Function	Address (decimal)	Nb of bits	Access type	Comment
Multiplying factor	0068	32	RW	
Tolerance statuses	0165	16	RO	Bit 0: Active tolerances Bit 1: Outside tolerances, reject Bit 2: Outside tolerances, rework Bit 3: Within tolerances Bit 5: Sensor error Bit 6: External tolerances Bit 7: Internal tolerances Bit 8: Outside Min/Max tolerances, reject Bit 9: Outside Min/Max tolerances, rework Bit 10: Within Min/Max tolerances Other bits reserved for future use
Access to bits 0064-0127	0400	4x16	RW	See corresponding bits
Last instrument error	8116	16		0: no error 1: Critical memory 2: Non-critical memory 3: RS232 hardware 4: RS232 software 5: RS485 hardware 6: RS485 software 7: RS485 collision 8: Sensor error

Function	Address (decimal)	Nb of bits	Access type	Comment
Last instrument error	8117	16		0: no error 1: Incorrect 32 bit access 2: Incorrect address 3: Inactive function 4: Invalid value 5: - 6: Empty variable 7: Invalid configuration 8: Protected variable
Date of last calibration	8200	32	RW	32 bit coded date format (see below)
Date of next calibration	8202	32	RW	32 bit coded date format (see below)
Software version	8450	32	RO	32 bit coded version format (see below)
Software version date	8452	32	RO	32 bit coded date format (see below)
RS485/ Modbus port transmission speed	8703	16	RW	Transmission speed format (see below)
USB/ RS232 port transmission speed	8704	16	RW	Transmission speed format (see below)

Function	Address (decimal)	Nb of bits	Access type	Comment
Instrument slave number	8705	16	R(W)	1..247 (0= unconfigured module) (Writing only possible by configuration procedure)
Instrument user number	8706	12x8	RW	XXXXXXXXXX
Project number	8950	16	RO	289
Type of instrument	8951	6x8	RO	PM289
Instrument factory number	9600	12x8	RO	ASCII character string

Variables formats

32 bit sensor position format (F32)

Bits 31..0: Floating point number coded according to IEEE754

Formatted sensor position format (F32) The format of the float value depends of :

Bits 0064...0127

Words 0060=Preset (when applicable) and 0068=Multiplying Factor

32 bit coded date format

Bits 7..0: Day (1-31)

Bits 15..8: Month (1-12)

Bits 31..16: Year (2000-2099)

00.00.0000: Indeterminate date

32 bit coded version format

Bits 7..0: Major ASCII version

Bits 15..8: Minor ASCII version in tens

Bits 23..16: Minor ASCII version in units

Bits 31..24: ASCII letter or space

Transmission speed format

0:	4,800 bauds	1:	9,600 bauds	2:	19,200 bauds
3:	38,400 bauds	4:	56,000 bauds	5:	57,600 bauds
6:	76,800 bauds	7:	115,200 bauds	8:	128,000 bauds
9:	187,500 bauds	10:	230,400 bauds	11:	256,000 bauds

A.3.3 Frame example

To read the current position of an instrument whose slave address is 03, send it the following frame :

03 04 00 02 00 02 CRC16, where

03 : The SLAVE address of instrument

04 : The Read n Register command

00 02 : The address of the 1st register to be read

00 02 : The number of registers to read

The answer will be :

03 04 04 xx xx xx xx CRC16, where

03 : The SLAVE address of instrument

04 : The Read n Register command

04 : The number of read data bytes

xx xx xx xx : The 4 read bytes

A.4 MODBUS exceptions codes

Exception mode	Description
01	Illegal function
02	Illegal address
03	Illegal data
04	Slave failure

B. Annexe ASCII Protocol

Default RS485 configuration for Ascii protocol :

128'000bauds

8 bits

Even parity

1 stop

Final CR

B.1 ASCII transactions

The master issues an ASCII Command frame on the bus. The addressed slave may or may not answer, depending of the Command.

B.2 Frame description

Command frame format

Address field (3..5 bytes)	Command field (any number of bytes)	End of Frame (1 byte)
----------------------------	-------------------------------------	-----------------------

Where :

Address field : The slave number (1...247, 0=reserved for broadcast)
 Format : #NNN# (NNN=1..3 ascii digits)

Note : if address field is fully omitted, the slave assumes it is the only one on the bus. If its own address is 0, it also answers without any address field, allowing a dialog compatible with Proximity commands, but on the RS485 bus. An answer is send on the bus in response to a bus request (not from keyboard, digital inputs or proximity).

Command field : Same as RS232-Proximity commands (see chapter 11)
End of Frame : Ascii CR (0x0D) or CRLF (0x0D, 0x0A)

Answer format

Address field (3..5 bytes)	Response field (any number of bytes)	End of Frame (1 byte)
----------------------------	--------------------------------------	-----------------------

Where :

Address field :	The slave number (same as Command)
Response field :	Same as RS232-Proximity answers (see chapter 12)
End of Frame :	Ascii CR (0x0D) or CRLF (0x0D, 0X0A)

C. Annexe ORBIT Protocol

Default RS485 configuration for Orbit protocol:

187'500 bauds

8 data bits

Odd parity

1 stop bit

C.1 ORBIT Transactions

The master issues an Orbit command frame on the bus. The addressed slave may or may not answer, depending of the command. For further details about the Orbit protocol, refer to the Solartron© ORBIT Protocol.

C.2 ORBIT Frames description

Command frame format

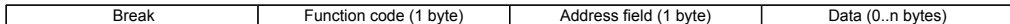

Break : The break condition of RS485 line (at least 11 bits @ 0)

Function code : See following table for supported Orbit functions

Address field : The slave number (ASCII 1..247, 0 = reserved for broadcast)

Data : 0..n bytes

Normal response frame format



Exception response frame format



Broadcast answer frame format

If the master issues a broadcast command, it doesn't expect an answer. The only exception is the Notify command "N" (see next page).

Table of supported PLC Comparator orbit functions

Command frame format

Function code	Description	Command format	Answer format	Available on Firmware V1.01P	Available on Firmware V1.02P
Commands (ascii byte)					
B	Get Info	<break> "B" ADR	"B" 4-bytes-module-type 2-bytes-hardware-type 2-bytes-resol 32-bytes-info	X	X
C	Clear	<break> "C" ADR	"C" ADR	X	X
G	Get Status	<break> "G" ADR	"G" 1-byte-error 2-bytes-status	X	X
I	Identify	<break> "I" ADR	"I" 10-bytes-ID 12-bytes-dev-type 5-bytes-version 2-bytes-stroke	X	X
L	Read2 (double word)	<break> "L" ADR	"L" 4-byte-probe-position	X	X
N	Notify	<break> "N" ADR_0	"N" 10-bytes-ID (answer only if probe has moved more than 1mm)	X	X
P	Preset	<break> "P" ADR 4-bytes-preset	"P" ADR	X	X
R	Reset	<break> "R" ADR	No answer	X	X

Function code	Description	Command format	Answer format	Available on Firmware V1.01P	Available on Firmware V1.02P
Commands (ascii byte)					
S	Set Address	<break> "S" ADR 10-bytes-ID 0x00	"S" ADR	X	X
V	Set Mode	<break> "V" ADR 2-bytes-Mode 2-bytes-Argument	"V" ADR		X
W	Control	<break> "W" 1-byte-Action	No answer		X
Exceptions					
0x00	Normal			X	X
0x01	Parity error		"!" 0x01	X	X
0x04	Broadcast not allowed		"!" 0x04	X	X
0x05	Broadcast expected		"!" 0x05	X	X
0x06	Address not allowed		"!" 0x06	X	X
0x09	Missing reading (bus is too slow)		"!" 0x09	X	X

Function code	Description	Command format	Answer format	Available on Firmware V1.01P	Available on Firmware V1.02P
0x0A	Extra reading (bus is too fast)		"!" 0x0A	X	X
0x12	Underrange Position		"!" 0x12	X	X
0x13	Overrange Position		"!" 0x13	X	X
0x40	Invalid Mode (of command "V")		"!" 0x40		
Statuts					
0x0004	Negative direction			X	X
0x0300	Synchronization mode				X
0x0400	Sample mode				X
0x0800	New reading available			X	X

Note : Multibytes parameters start with LSB first

Example of PLC answer

Commands (ascii byte)	Parameters	Exemple	Explanation
"B"	4-bytes-module-type 2-bytes-hardware-type 2-bytes-resol 32-bytes-info	"LE25" 0x0001 0x0064 "V102P[-xx] 01.02.16" "MMR3D+D0F1"	Linear Encoder 25mm type 1 In nm x 10 -> 100 x 0.01um = 1um Firmware version[-options] date 2 characters for each of up to 7 options MM or IN or MO or IO (mm/inch or only) R2 or R3 or R_ (0.001um/0.1um/no resol) D+ or D- or D_ (Direction +/- no dir) D0 or D1 or D_ (Radius/Diameter/no diam) F1 or F2 or F_ (Reference 1/2/no ref)
"G"	1-byte-error 2-bytes-status		See Exceptions codes for 1-byte-error See Status codes for 2-bytes-status
"I"	10-bytes-ID 12-bytes-dev-type 5-bytes-version 2-bytes-stroke	"9#L1" "yywwnn" "SYL289-LE095" "102P " 0x0019	Sylvac instrument Year week number Sylvac PM289-Linear Encoder type .950 Firmware version Stroke in mm (or inch)
"L"	"L" 4-byte-probe-position	Returns a 32 bits float value expressed in um	Returns 0x7FFFFFFF in case of sensor error
"N"	10-bytes-ID	"9#L1" "yywwnn"	Sylvac instrument Year week number (the instrument sends its ID only if probe has moved more than 1mm)

Master parameters sent to the instrument

Commands (ascii byte)	Parameters	Explanation
"P"	4-bytes-preset	A new 32 bits float preset value expressed in μm
"S"	10-bytes-ID	If 10-bytes-ID matches the received ID, then instrument stores its new address. New address : 0...247 (0 for unconfigure the instrument)
"V"	2-bytes-Mode 2-bytes-Argument	Mode 0x0000 : normal mode 0x000A : synchronized mode (not used) 0x0014 : sampled mode Argument : not used
"W"	1-byte-Action	Action 0x00 : clears memory (not used) 0x01 : starts synchronization (not used) 0x02 : stops synchronization (not used) 0x03 : takes and stores a sample (reads it with "L")

CERTIFICATE OF CONFORMITY

We certify that this instrument has been manufactured in accordance with our Quality Standard and tested with reference to masters of certified traceability by the National Office of Metrology.

CERTIFICAT DE CONFORMITE

Nous certifions que cet instrument a été fabriqué et contrôlé selon nos normes de qualité et en référence avec des étalons dont la traçabilité est reconnue par l'office national de métrologie.

QUALITÄTSZEUGNIS

Wir bestätigen, dass dieses Gerät gemäss unseren internen Qualitätsnormen hergestellt wurde und mittels Normalen mit anerkannter Rückverfolgbarkeit, kalibriert durch das Nationalamt für Metrologie, geprüft worden ist.

CERTIFICATO DI CONFORMITÀ

Con il presente si certifica che questo strumento è stato prodotto secondo il nostro standard sulla qualità e controllato rispetto a campioni di riferibilità riconosciuta dall'ufficio nazionale di metrologia

CERTIFICADO DE CONFORMIDAD

Certificamos que este instrumento ha sido fabricado conforme a nuestras normas de calidad y ha sido controlado en relación con patrones de trazabilidad reconocida por la oficina nacional de metrología.

Calibration certificate

Because we make our instruments in batches, you may find that the date on your calibration certificate is not current. Please be assured that your instruments are certified at point of production and then held in stock in our warehouse in accordance with our Quality Management System ISO 9001. Re-calibration cycle should start from date of receipt.

Certificat d'étalonnage

En raison de la fabrication de nos instruments par lots de production, il est possible que la date de votre certificat d'étalonnage ne soit pas actuelle. Nous garantissons que nos instruments sont certifiés au moment de leur fabrication puis stockés conformément à notre système de gestion de la qualité ISO 9001. Le cycle de réétalonnage peut commencer à partir de la date de réception.

Zertifikat

Da wir unsere Instrumente in Serien herstellen, kann es sein, dass das Datum auf dem Zertifikat nicht aktuell ist. Die Instrumente sind jedoch ab der Herstellung zertifiziert und werden dann gemäß unserem Qualitätsmanagementsystem ISO 9001 in unserem Lager aufbewahrt. Der Nachkalibrierungszyklus kann ab dem Empfangsdatum beginnen.

Certificado de calibración

Puesto que fabricamos nuestros instrumentos por lotes, puede que la fecha de su informe de prueba / certificado de calibración no esté al día. Asegúrese de que los instrumentos estén certificados en nuestro lugar de producción y estén almacenados en nuestro almacén conforme a nuestro sistema de control de calidad ISO 9001. El ciclo de recalibración puede empezar a partir de la fecha de recepción.

Certificato di taratura

Considerata la nostra produzione in serie di strumenti, è possibile verificare che la data di produzione sul rapporto di prova / certificato di taratura non è attuale. Accertarsi che gli strumenti siano correttamente certificati dalla nostra produzione e che sono conservati in stock presso il nostro magazzino secondo il sistema di gestione della qualità ISO 9001. Il ciclo di nuova taratura può essere avviato dalla data di ricezione.

UK
CA



Changes without prior notice

Sous réserve de toute modification

Änderungen vorbehalten

Soggetto a modifica senza preavviso

Reservados los derechos de modificación sin previo aviso

Edition: 2021.07 / 681-289-07