

Special Type Test Indicators

Large dial face D series

The dial plate size of PCN-1A, PCN-1L, PCN-2B, and PCN-S models has been enlarged, with easy reading due to the larger scale spacing, as a result. Screw type long stems are standard for these large dial face test indicators.

Without change lever type (CW rotation only)

Special Type Test Indicators



PCN-1AD
Graduation: 0.01mm
Range: 0.5mm

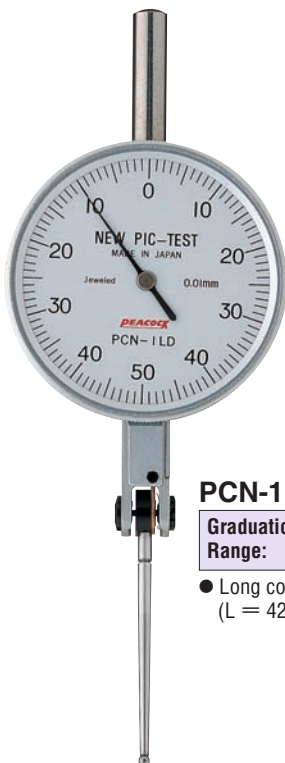

PCN-1LD
Graduation: 0.01mm
Range: 1mm
● Long contact point (L = 42.8mm)



PCN-2BD
Graduation: 0.002mm
Range: 0.2mm

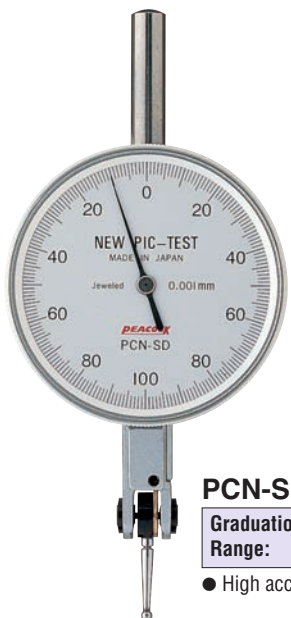

PCN-SD
Graduation: 0.001mm
Range: 0.2mm
● High accuracy

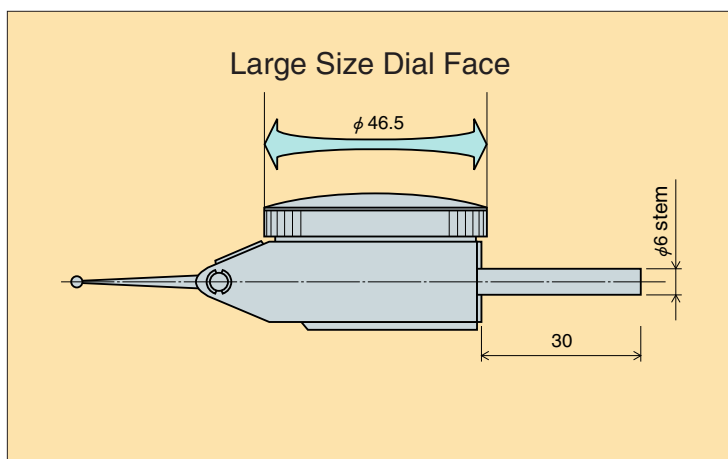

Specifications

Model	Graduation (mm)	Range (mm)	Reading	Accuracy (μm)			Measuring force less than(N)
				Wide-range forward accuracy	Adjacent error	Backward error	
PCN-1AD	0.01	0.5	0 - 25 - 0	5	5	3	0.3
PCN-1LD	0.01	1.0	0 - 50 - 0	10	5	4	0.3
PCN-2BD	0.002	0.2	0 - 100 - 0	3	2	2	0.3
PCN-SD	0.001	0.2	0 - 100 - 0	3	2	2	0.3